



LISTING INFORMATION OF

**GCP Applied Technologies Inc. - Monokote® MK-6®/HY®,  
MK-10®/HB®, MK-10®/HB® Extended Set, MK-1000®/HB®,  
and MK-1000®/HB® Extended Set**

SPEC ID: 25777

GCP Applied Technologies Inc.  
62 Whittemore Avenue  
Cambridge, MA 02140

This report is for the exclusive use of Intertek's Client and is provided pursuant to the agreement between Intertek and its Client. Intertek's responsibility and liability are limited to the terms and conditions of the agreement. Intertek assumes no liability to any party, other than to the Client in accordance with the agreement, for any loss, expense or damage occasioned by the use of this report. Only the Client is authorized to permit copying or distribution of this report and then only in its entirety. Any use of the Intertek name or one of its marks for the sale or advertisement of the tested material, product or service must first be approved in writing by Intertek. The observations and test results in this report are relevant only to the sample tested. This report by itself does not imply that the material, product, or service is or has ever been under an Intertek certification program.

## LISTING INFORMATION

Monokote® MK-6®/HY®, MK-10®/HB®, MK-10®/HB® Extended Set, MK-1000®/HB®, and MK-1000®/HB® Extended Set are single component, spray applied, mill-mixed fireproofing plaster. The products are used on structural steel columns, beams, concrete and fluted decking to provide various hourly fire ratings based on its applied thickness. Monokote® MK-6®/HY®, MK-10®/HB®, MK-10®/HB® Extended Set, MK-1000®/HB®, and MK-1000®/HB® Extended Set are gypsum based cementitious spray-applied fireproofing intended for interior application to steel and concrete substrates, and Intertek's current product certification is approved for interior use only.

### EVALUATED TO THE FOLLOWING

ASTM E119, Fire Tests of Building Construction and Materials  
 UL 263, Standard for Safety Fire Tests of Building Construction and Materials  
 NFPA 251 Standard Methods of Tests of Fire Resistance of Building Construction and Materials  
 Reference Design Listing GCP/CF 194-01 for ratings.

<b>Attribute</b>	<b>Value</b>
Criteria	ANSI / UL 263 (2003)
Criteria	NFPA 251 (2006)
Criteria	ASTM E119 (2008a)
Criteria	ASTM E119 (2014)
Criteria	ASTM E119 (2018a)
CSI Code	07 81 00 Applied Fireproofing
Intertek Services	Certification
Listed or Inspected	LISTED
Listing Section	ROOF/CEILING, FLOOR/CEILING, BEAM & COLUMN ASSEMBLIES
Spec ID	25777

## DRAWING INDEX

GCP/CF 194-01

# GCP/CF 194-01



07 80 00 Fire and Smoke Protection  
 07 81 00 Applied Fireproofing  
 07 81 16 Cementitious Fireproofing

**GCP Applied Technologies Inc.**  
**Design No. GCP/CF 194-01**  
**Monokote® MK-6®/HY, MK-10®/HB, MK-10®/HB Extended Set, MK-1000®/HB, and MK-1000®/HB**  
**Extended Set**  
**LOADED RESTRAINED OR UNRESTRAINED COMPOSITE BEAM**  
**ASTM E 119-08a**  
**Fire Resistive Beam Assembly Rating – Refer to Tables**

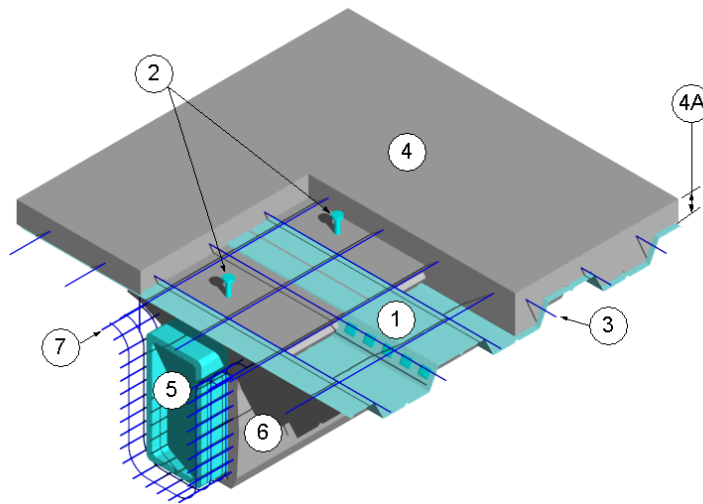

- 1. COMPOSITE STEEL FLOOR DECK:** Fluted deck made from sheet steel conforming to ASTM A1008 (A1008M) with a min. yield strength of 33 ksi (230 MPa), or select other acceptable structural sheet steels or high strength low alloy steels from the North American Specification for the Design of Cold-Formed Steel Structural Members, and 1 1/2 in., 2 in. or 3 in. deep flutes with a min. design thickness of 0.0474 in., welded to top of structural steel box beam (Item 5) and covered with min. concrete (Item 4) requirements as required herein.
- 2. SHEAR STUD CONNECTORS:** Puddle weld min. 1/2 in. diameter by steel studs to composite steel floor deck (Item 1) and structural steel box beam (Item 5) providing a nominal

concrete cover over the steel stud heads as required. Install shear stud connectors per AISC guidelines to provide a nominal 50% composite action between the beam and the concrete deck assembly.

- 3. CONCRETE REINFORCEMENT:** Non-structural applications – Use min. 6 x 6 in. 10/10 SWG wire mesh installed mid depth of concrete (Item 4) topping or

**A. LISTED MANUFACTURER:** GCP Applied Technologies Inc.

**LISTED PRODUCT:** STRUX®

**MODEL:** 90/40

Date Revised: November 28, 2018

Page 1 of 6

Project No. G103524371

Version: 02 August 2017

SFT-BC-OP-19I

**GCP/CF 194-01 (2 OF 6)**

Use a proprietary synthetic macro fiber reinforcement made of polypropylene/polyethylene fibers distributed at a rate of 5 lbs/yd<sup>3</sup> of concrete (Item 4) conforming to ASTM C 1116.

4. **CONCRETE:** Use min. compressive strength of 3000 psi.
  - A. Place concrete topping (as measured from top of composite steel floor deck (Item 1) to wearing surface of concrete) min. 2-1/2 in. thick.
  - B. Apply a min. concrete volume to the area of composite steel floor deck to achieve min. hourly fire resistive rating of floor/ceiling assembly using either:
    - C. Use normal weight concrete having approximately 148 pcf with either siliceous or carbonate aggregate.
    - D. Use lightweight concrete having approximately 110 pcf.
5. **STRUCTURAL STEEL BOX BEAM:** Use hollow steel sections (HSS) having nominal A/P section factors based on three-sided exposure with one short, or equal when square, surface in contact with composite steel floor deck (Item 1) and the other short, or equal when square, surface exposed. Applied fireproofing (Item 6) thickness for nominal A/P section factors based on one short, or equal when square, in contact with composite steel floor deck (Item 1) and the other short, or equal when square, exposed applicable to any HSS beam orientation. Refer to Tables 1-3 for specific application thickness of applied fireproofing (Item 6). Refer to Table 4 for A/P section factors for select HSS.
6. **CERTIFIED MANUFACTURER:** GCP Applied Technologies Inc.

07 80 00 Fire and Smoke Protection  
 07 81 00 Applied Fireproofing  
 07 81 16 Cementitious Fireproofing

**CERTIFIED PRODUCT:** Monokote®

**MODEL:** MK6®/HY, MK10®/HB, MK10®/HB Extended Set, MK1000®/HB, and MK1000®/HB Extended Set

**APPLIED FIREPROOFING:** Install applied fireproofing in accordance with appropriate Table for beam and concrete conditions. Mix applied fireproofing with water and apply it using the equipment recommended by the certified applied-fireproofing manufacturer. Injection of an accelerator into the fireproofing at the nozzle of the spray gun during application is optional. Apply only to clean and dry surfaces only: free of loose scale and oil. Completely fill all voids (flutes) between composite steel floor deck (Item 1) and structural steel box beam (Item 5) with applied fireproofing. Apply in multiple coats to achieve min. thickness of applied fireproofing to three exposed sides of structural steel box beam (Item 5) as noted in appropriate Table. Allow each coat to set before applying next coat. Applied fireproofing, dried density calculated per ASTM E 605: nominal 15 pcf and min. density 14 pcf.

**FIREPROOFING REINFORCEMENT:** When the A/P section factor is less than 0.616 and the applied thickness of the spray applied fireproofing material is thicker than 1 3/16 in. fireproofing reinforcement is required. Prior to installing the applied fireproofing, position a min. 1-1/2 x 1-1/2 in. 20 GA twisted wire mesh around the three exposed sides of structural steel box beam (Item 5) nominally at mid thickness of applied fireproofing (Item 6). Mechanically fasten the mesh to composite steel floor deck (Item 1) by means of screws, welds or power-actuated fasteners, parallel to the top flange and staggered at 8 in. on center on both sides of the structural steel box beam (Item 5).

Date Revised: November 28, 2018

Page 2 of 6

Project No. G103524371

Version: 02 August 2017

SFT-BC-OP-191

# GCP/CF 194-01 (3 OF 6)



07 80 00 Fire and Smoke Protection  
 07 81 00 Applied Fireproofing  
 07 81 16 Cementitious Fireproofing

**TABLE 1 – Restrained Beam & Normal Weight Concrete  
 Fire Resistance Time in Minutes (Hours)**

Section Factor A/P inches	60 (1)	90 (1-1/2)	120 (2)	150 (2 1/2)	180 (3)
	<b>MINIMUM Monokote® Thickness (Inches)</b> (A/P Section Factor based on Three Sided Exposure with One Short or Equal Surface Exposed) Fireproofing reinforcement required when thickness is marked in red bold				
0.984	5/16	7/16	5/8	13/16	1
0.875	5/16	1/2	11/16	7/8	1 1/8
0.787	5/16	1/2	3/4	15/16	1 3/16
0.716	5/16	9/16	13/16	1	1 1/4
0.656	5/16	9/16	13/16	1 1/16	1 5/16
0.606	5/16	5/8	7/8	1 1/8	1 3/8
0.562	3/8	5/8	15/16	1 3/16	1 1/2
0.525	3/8	11/16	15/16	1 1/4	1 1/2
0.492	3/8	11/16	1	1 5/16	1 9/16
0.463	3/8	11/16	1	1 5/16	1 5/8
0.437	3/8	3/4	1 1/16	1 3/8	1 11/16
0.414	7/16	3/4	1 1/16	1 7/16	1 3/4
0.394	7/16	3/4	1 1/8	1 7/16	1 13/16
0.375	7/16	13/16	1 1/8	1 1/2	1 7/8
0.358	7/16	13/16	1 3/16	1 1/2	1 7/8
0.342	7/16	13/16	1 3/16	1 9/16	1 15/16
0.328	7/16	13/16	1 1/4	1 5/8	2
0.315	1/2	7/8	1 1/4	1 5/8	2
0.303	1/2	7/8	1 1/4	1 11/16	2 1/16
0.292	1/2	7/8	1 5/16	1 11/16	2 1/16
0.281	1/2	7/8	1 5/16	1 11/16	2 1/8
0.272	1/2	15/16	1 5/16	1 3/4	2 1/8
0.262	1/2	15/16	1 3/8	1 3/4	2 3/16
0.254	1/2	15/16	1 3/8	1 13/16	2 3/16
0.246	1/2	15/16	1 3/8	1 13/16	2 1/4
0.239	9/16	15/16	1 3/8	1 13/16	2 1/4
0.232	9/16	1	1 7/16	1 7/8	2 5/16
0.225	9/16	1	1 7/16	1 7/8	2 5/16
0.219	9/16	1	1 7/16	1 7/8	2 3/8
0.213	9/16	1	1 7/16	1 15/16	2 3/8
0.207	9/16	1	1 1/2	1 15/16	2 3/8
0.202	9/16	1	1 1/2	1 15/16	2 7/16
0.197	9/16	1 1/16	1 1/2	2	2 7/16
0.192	9/16	1 1/16	1 1/2	2	2 7/16
0.187	9/16	1 1/16	1 1/2	2	2 1/2

# GCP/CF 194-01 (4 OF 6)



07 80 00 Fire and Smoke Protection  
 07 81 00 Applied Fireproofing  
 07 81 16 Cementitious Fireproofing

TABLE 2 – Unrestrained Beam & Normal Weight Concrete					
Fire Resistance Time in Minutes (Hours)					
Section Factor A/P inches	60 (1)	90 (1-1/2)	120 (2)	150 (2 1/2)	180 (3)
	MINIMUM Monokote® Thickness (Inches) (A/P Section Factor based on Three Sided Exposure with One Short or Equal Surface Exposed) <b>Fireproofing reinforcement required when thickness is marked in red bold</b>				
0.984	5/16	7/16	11/16	7/8	1 1/16
0.875	5/16	1/2	3/4	15/16	1 1/8
0.787	5/16	9/16	3/4	1	1 1/4
0.716	5/16	9/16	13/16	1 1/16	1 5/16
0.656	3/8	5/8	7/8	1 1/8	1 3/8
0.606	3/8	5/8	15/16	1 3/16	1 1/2
0.562	3/8	11/16	15/16	1 1/4	1 9/16
0.525	3/8	11/16	1	1 5/16	1 5/8
0.492	7/16	3/4	1 1/16	1 3/8	1 11/16
0.463	7/16	3/4	1 1/16	1 7/16	1 3/4
0.437	7/16	13/16	1 1/8	1 7/16	1 13/16
0.414	7/16	13/16	1 3/16	1 1/2	1 7/8
0.394	1/2	13/16	1 3/16	1 9/16	1 7/8
0.375	1/2	7/8	1 1/4	1 9/16	1 15/16
0.358	1/2	7/8	1 1/4	1 5/8	2
0.342	1/2	7/8	1 1/4	1 11/16	2 1/16
0.328	1/2	15/16	1 5/16	1 11/16	2 1/8
0.315	1/2	15/16	1 5/16	1 3/4	2 1/8
0.303	9/16	15/16	1 3/8	1 3/4	2 3/16
0.292	9/16	15/16	1 3/8	1 13/16	2 1/4
0.281	9/16	1	1 7/16	1 13/16	2 1/4
0.272	9/16	1	1 7/16	1 7/8	2 5/16
0.262	9/16	1	1 7/16	1 7/8	2 5/16
0.254	9/16	1	1 1/2	1 15/16	2 3/8
0.246	9/16	1 1/16	1 1/2	1 15/16	2 3/8
0.239	5/8	1 1/16	1 1/2	2	2 7/16
0.232	5/8	1 1/16	1 1/2	2	2 7/16
0.225	5/8	1 1/16	1 9/16	2	2 1/2
0.219	5/8	1 1/8	1 9/16	2 1/16	2 1/2
0.213	5/8	1 1/8	1 9/16	2 1/16	2 9/16
0.207	5/8	1 1/8	1 5/8	2 1/16	2 9/16
0.202	5/8	1 1/8	1 5/8	2 1/8	2 5/8
0.197	5/8	1 1/8	1 5/8	2 1/8	2 5/8
0.192	5/8	1 1/8	1 5/8	2 1/8	2 5/8
0.187	11/16	1 3/16	1 11/16	2 3/16	2 11/16

GCP/CF 194-01 (5 OF 6)



07 80 00 Fire and Smoke Protection  
 07 81 00 Applied Fireproofing  
 07 81 16 Cementitious Fireproofing

**TABLE 3 – Restrained or Unrestrained Beam & Lightweight Weight Concrete  
 Fire Resistance Time in Minutes (Hours)**

Section Factor A/P inches	60 (1)	90 (1-1/2)	120 (2)	150 (2 1/2)	180 (3)
	<b>MINIMUM Monokote® Thickness (Inches)</b> (A/P Section Factor based on Three Sided Exposure with One Short or Equal Surface Exposed) Fireproofing reinforcement required when thickness is marked in red bold				
0.984	5/16	7/16	11/16	7/8	1 1/16
0.875	5/16	1/2	3/4	15/16	1 1/8
0.787	5/16	9/16	3/4	1	1 1/4
0.716	5/16	9/16	13/16	1 1/16	1 5/16
0.656	3/8	5/8	7/8	1 1/8	1 3/8
0.606	3/8	5/8	15/16	1 3/16	1 1/2
0.562	3/8	11/16	15/16	1 1/4	1 9/16
0.525	3/8	11/16	1	1 5/16	1 5/8
0.492	7/16	3/4	1 1/16	1 3/8	1 11/16
0.463	7/16	3/4	1 1/16	1 7/16	1 3/4
0.437	7/16	13/16	1 1/8	1 7/16	1 13/16
0.414	7/16	13/16	1 3/16	1 1/2	1 7/8
0.394	1/2	13/16	1 3/16	1 9/16	1 7/8
0.375	1/2	7/8	1 1/4	1 9/16	1 15/16
0.358	1/2	7/8	1 1/4	1 5/8	2
0.342	1/2	7/8	1 1/4	1 11/16	2 1/16
0.328	1/2	15/16	1 5/16	1 11/16	2 1/8
0.315	1/2	15/16	1 5/16	1 3/4	2 1/8
0.303	9/16	15/16	1 3/8	1 3/4	2 3/16
0.292	9/16	15/16	1 3/8	1 13/16	2 1/4
0.281	9/16	1	1 7/16	1 13/16	2 1/4
0.272	9/16	1	1 7/16	1 7/8	2 5/16
0.262	9/16	1	1 7/16	1 7/8	2 5/16
0.254	9/16	1	1 1/2	1 15/16	2 3/8
0.246	9/16	1 1/16	1 1/2	1 15/16	2 3/8
0.239	5/8	1 1/16	1 1/2	2	2 7/16
0.232	5/8	1 1/16	1 1/2	2	2 7/16
0.225	5/8	1 1/16	1 9/16	2	2 1/2
0.219	5/8	1 1/8	1 9/16	2 1/16	2 1/2
0.213	5/8	1 1/8	1 9/16	2 1/16	2 9/16
0.207	5/8	1 1/8	1 5/8	2 1/16	2 9/16
0.202	5/8	1 1/8	1 5/8	2 1/8	2 5/8
0.197	5/8	1 1/8	1 5/8	2 1/8	2 5/8
0.192	5/8	1 1/8	1 5/8	2 1/8	2 5/8
0.187	11/16	1 3/16	1 11/16	2 3/16	2 11/16



GCP/CF 194-01 (6 OF 6)



07 80 00 Fire and Smoke Protection  
 07 81 00 Applied Fireproofing  
 07 81 16 Cementitious Fireproofing

**TABLE 4 – A/P Section Factors for Select Rectangular HSS for Three-Sided Exposure\***

AISC HSS Designation	A/P	AISC HSS Designation	A/P	AISC HSS Designation	A/P
24 X 12 X 3/4	0.785	18 X 6 X 1/4	0.257	14 X 10 X 1/2	0.550
24 X 12 X 5/8	0.660	16 X 16 X 7/8	0.994	14 X 10 X 3/8	0.421
24 X 12 X 1/2	0.535	16 X 16 X 3/4	0.865	14 X 10 X 5/16	0.353
22 X 22 X 7/8	1.020	16 X 16 X 5/8	0.729	14 X 10 X 1/4	0.284
22 X 22 X 3/4	0.882	16 X 16 X 1/2	0.590	14 X 6 X 5/8	0.618
20 X 20 X 7/8	1.013	16 X 16 X 3/8	0.448	14 X 6 X 1/2	0.506
20 X 20 X 3/4	0.877	16 X 16 X 5/16	0.377	14 X 6 X 3/8	0.388
20 X 20 X 5/8	0.738	16 X 12 X 3/4	0.816	14 X 6 X 5/16	0.326
20 X 20 X 1/2	0.597	16 X 12 X 5/8	0.689	14 X 6 X 1/4	0.264
20 X 12 X 3/4	0.798	16 X 12 X 1/2	0.559	14 X 6 X 3/16	0.199
20 X 12 X 5/8	0.673	16 X 12 X 3/8	0.425	14 X 4 X 5/8	0.584
20 X 12 X 1/2	0.544	16 X 12 X 5/16	0.357	14 X 4 X 1/2	0.478
20 X 12 X 3/8	0.413	16 X 8 X 5/8	0.643	14 X 4 X 3/8	0.369
20 X 12 X 5/16	0.348	16 X 8 X 1/2	0.523	14 X 4 X 5/16	0.310
20 X 8 X 5/8	0.631	16 X 8 X 3/8	0.400	14 X 4 X 1/4	0.251
20 X 8 X 1/2	0.513	16 X 8 X 5/16	0.335	14 X 4 X 3/16	0.189
20 X 8 X 3/8	0.390	16 X 8 X 1/4	0.270	12 X 12 X 3/4	0.842
20 X 8 X 5/16	0.327	16 X 4 X 5/8	0.583	12 X 12 X 5/8	0.714
20 X 4 X 1/2	0.475	16 X 4 X 1/2	0.478	12 X 12 X 1/2	0.581
20 X 4 X 3/8	0.364	16 X 4 X 3/8	0.367	12 X 12 X 3/8	0.444
20 X 4 X 5/16	0.305	16 X 4 X 5/16	0.308	12 X 12 X 5/16	0.372
20 X 4 X 1/4	0.245	16 X 4 X 1/4	0.249	12 X 12 X 1/4	0.300
18 X 18 X 7/8	1.006	16 X 4 X 3/16	0.188	12 X 12 X 3/16	0.226
18 X 18 X 3/4	0.872	14 X 14 X 7/8	0.981	12 X 10 X 1/2	0.559
18 X 18 X 5/8	0.733	14 X 14 X 3/4	0.855	12 X 10 X 3/8	0.429
18 X 18 X 1/2	0.594	14 X 14 X 5/8	0.721	12 X 10 X 5/16	0.359
18 X 6 X 5/8	0.612	14 X 14 X 1/2	0.586	12 X 10 X 1/4	0.291
18 X 6 X 1/2	0.498	14 X 14 X 3/8	0.445	12 X 8 X 5/8	0.656
18 X 6 X 3/8	0.381	14 X 14 X 5/16	0.374	12 X 8 X 1/2	0.538
18 X 6 X 5/16	0.319	14 X 10 X 5/8	0.676	12 X 8 X 3/8	0.413

\*Note: A/P values above were calculated using data from AISC Shapes Database V15.0 and equation shown below; use this method to calculate A/P for other HSS not listed above.

<b>A</b>	Cross-sectional area, in. <sup>2</sup>
<b>Ht</b>	Overall depth of square or rectangular HSS, in.
<b>B</b>	Overall width of square or rectangular HSS, in.
<b>A/P</b>	$A/(2Ht + B)$