

WINDOW PRESTRIP VARIATIONS

A. WITHOUT BACK DAM ANGLE

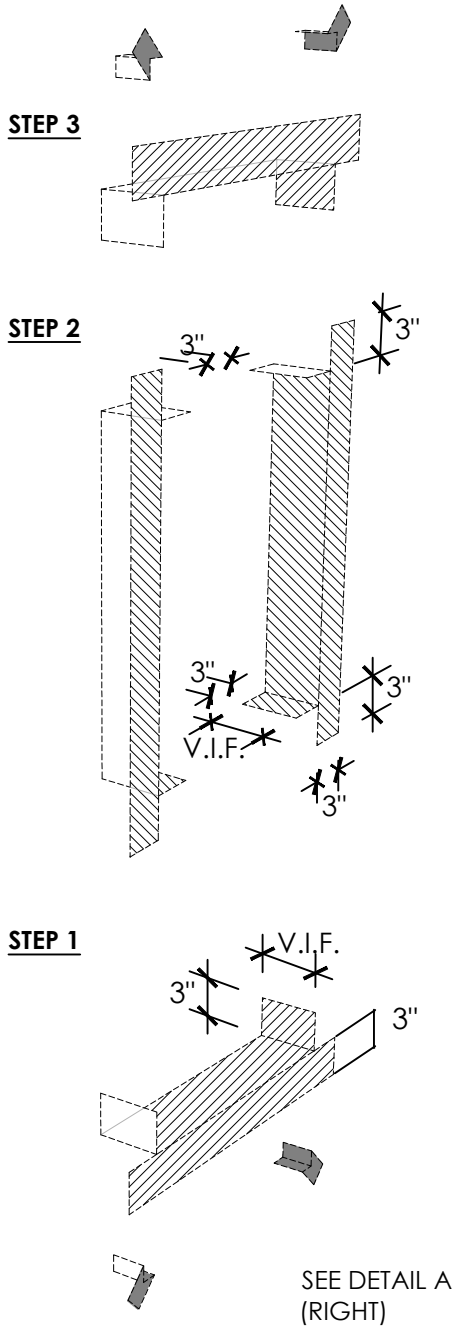

B. WITH BACK DAM ANGLE

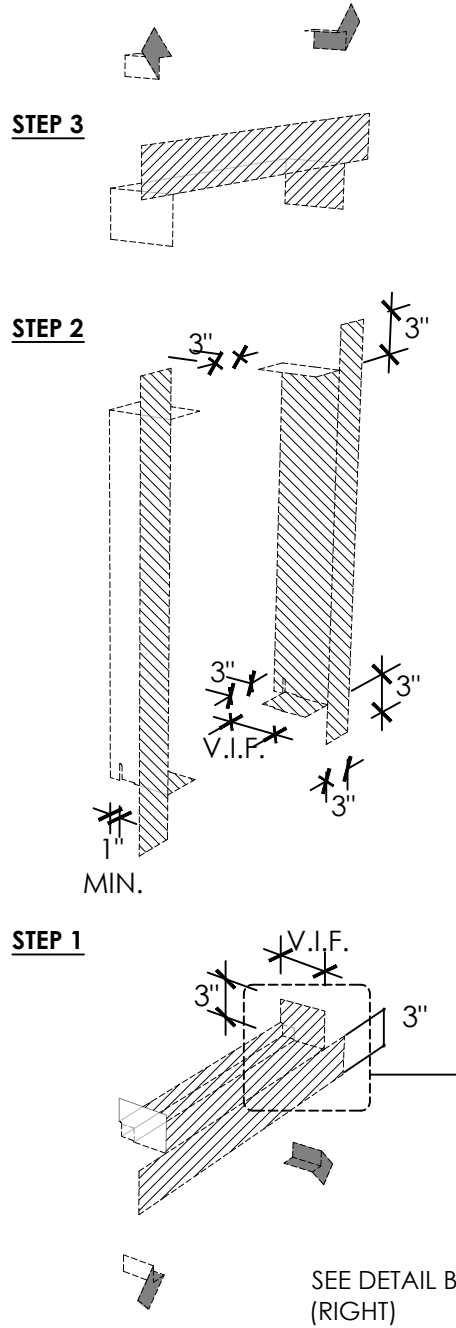

LEGEND

- WINDOW PRESTRIP PERM-A-BARRIER® DETAIL MEMBRANE, NPS DETAIL MEMBRANE, ALUMINUM FLASHING, OR WALL FLASHING
- PRIME SUBSTRATE WHERE REQUIRED

DETAIL A

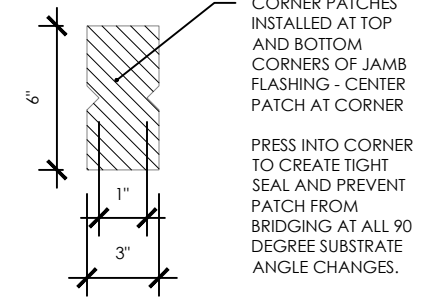

DETAIL B

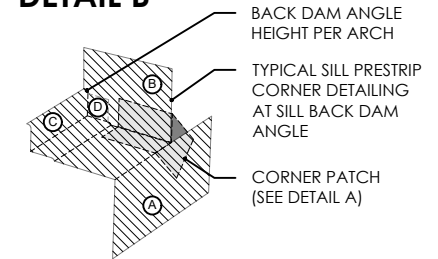

FOLDING TEMPLATE

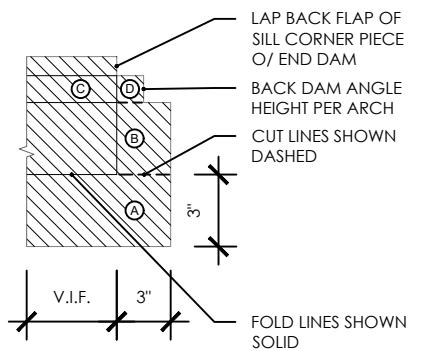

GENERAL NOTES

1. Detail not suitable for all climates. Avoiding excessive moisture accumulation in exterior walls is dependent on many factors including proper placement of insulation and water, air, and vapor control layers in the wall. Confirm membranes are suitable for project specific service temperatures. For assistance with exterior wall design, consult with a building science professional.
2. Install all GCP products in accordance with GCP Product Data Sheets and GCP recommendations.
3. GCP products are indicated in the detail legend in **BOLDFACE** font. Detail components by others are indicated in GRAY FONT. Install components per manufacturer and project specific requirements.

Refer to air barrier system product data sheet for acceptable SELF-ADHERED FLASHING products.



SHEET-APPLIED FLASHING PRESTRIP

PERM-A-BARRIER® NPS
MEMBRANE

DRAWING: NPS-003 (3D-2)

SCALE: 3" = 1'

EFFECTIVE DATE: 2020.05.21

SUPERCEDES: NEW